

leggett & platt®

fashion home™

6755 W. 65th Street Bedford Park, IL 60638

Parts List For Bar Stool # C1M080

BAR STOOL CARTON

- (6) METAL SEAT RING-1
- (7) LEGS-4
- (8) FOOT REST METAL RING-1
- (9) BACK PANEL-1

PART #390902 HARDWARE BAG

- (1) 1/4-20 X 7/8" FLAT ALLEN HEAD SCREW-6
  - (2) 1/4" ID METAL SPRING WASHER-12
  - (3) 1/4" ID X 1/4" OD FLAT METAL WASHER-12
  - (4) 1/4-20 X 5/8" FLAT ALLEN HEAD SCREW-10
  - (5) ALLEN WRENCH-1
- (10) PLASTIC GLIDE -4 #389702 (PRE-INSTALLED)

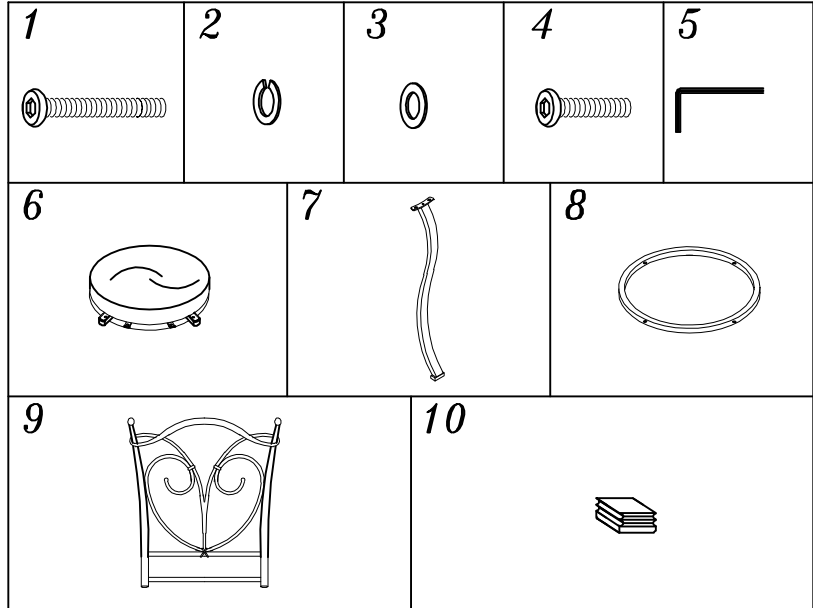

SAVE ALL PACKAGING MATERIALS UNTIL PRODUCT IS FULLY ASSEMBLED. HARDWARE AND SMALL PIECES MAY NOT BE SEEN AND COULD BE ACCIDENTALLY DISCARDED WITH PACKAGING MATERIALS.

PRODUCT FULLY ASSEMBLED

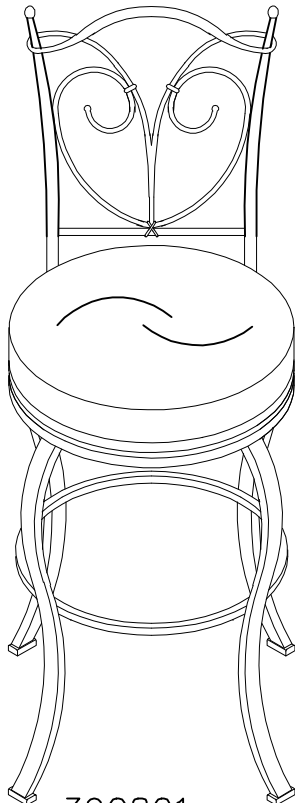

FOR ASSISTANCE IN ASSEMBLY ONLY OF THIS PRODUCT, CALL OUR HELP DESK AT 1-800-324-3415, BETWEEN 8:30 AM & 4:30 PM CENTRAL TIME MONDAY THROUGH FRIDAY. PLEASE HAVE THE STYLE NUMBER AVAILABLE BEFORE YOU CALL. (STYLE # OR NAME CAN BE FOUND ON PACKING CARTON OR SALES RECEIPT.) OUR PRODUCT IS INSPECTED TO ENSURE IT IS IN GOOD CONDITION. IF YOUR FURNITURE APPEARS TO HAVE BEEN DAMAGED IN SHIPMENT OR YOU ARE IN NEED OF REPLACEMENT PARTS PLEASE CONTACT THE DEALER FROM WHOM YOU PURCHASED THE PRODUCT.

# Instruction Sheet

## Step 1- Assembly of Legs to Metal Seat Ring.

- Align holes on leg metal bracket (7) with threaded holes on metal seat ring (6), and secure leg (7) with screw (4), spring washer (2) and flat metal washer (3). SEE FIGURE 1  
DO NOT TIGHTEN SCREWS COMPLETELY

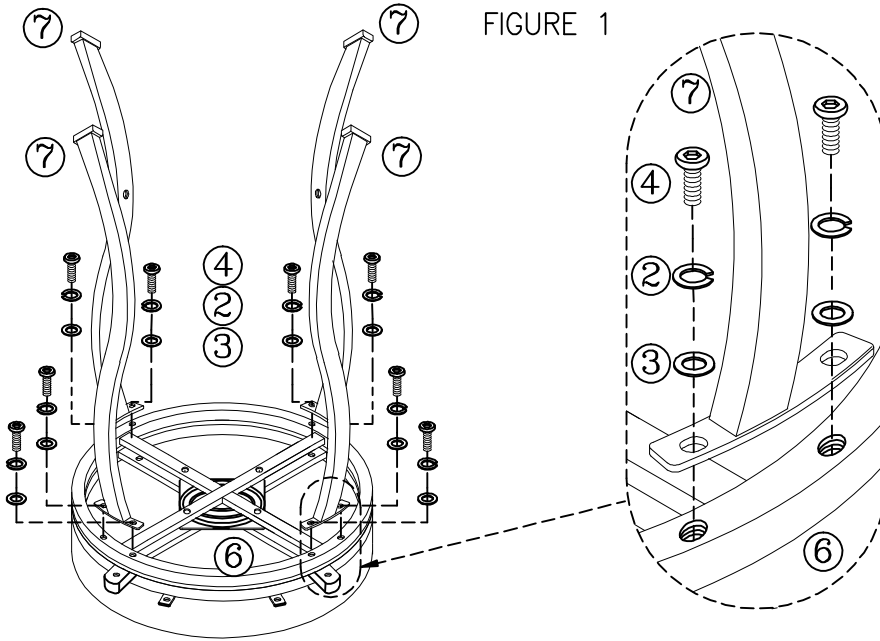

FIGURE 1

## Step 2- Assembly of Foot Rest Metal Ring to Legs.

- Place bar stool legs on flat surface. SEE FIGURE 2
- Place foot rest metal ring (8) between legs (7), align pilot holes on foot rest metal ring (8) with threaded holes on legs (7) and secure foot rest metal ring (8) into legs (7) with screw (1). Tighten screws with Allen wrench (5). SEE FIGURE 2  
NOW TIGHTEN ALL SCREWS (4) COMPLETELY. FROM STEP 1 (FIGURE 1)

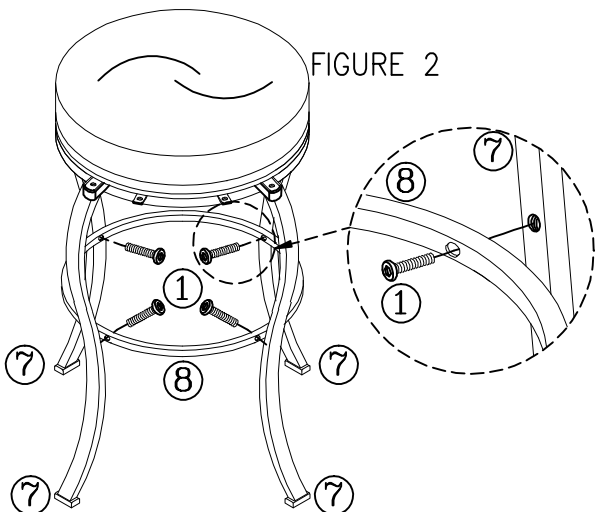

FIGURE 2

## Step 3- Assembly of Back Panel to Seat.

- Insert post of back panel (9) into metal bracket on seat (6). SEE FIGURE 3
- Secure back panel (9) to seat bracket with screw (1), spring washer (2) and flat metal washer (3). Tighten screws with Allen wrench (5).
- Secure bottom rail on back panel (9) with screw (4), spring washer (2) and flat metal washer (3). SEE FIGURE 3

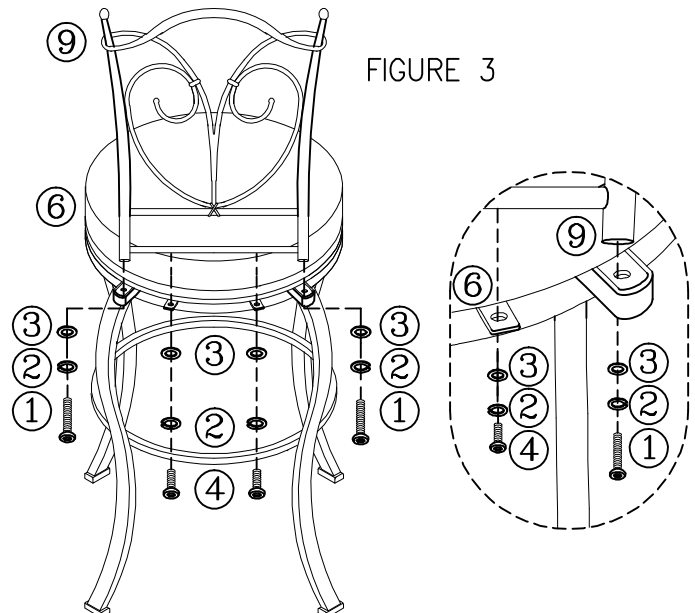

FIGURE 3